

## Viscometer Installation Guidelines

### Summary

*The SenGenuity line of solid-state digital viscometers offers significant advantages over conventional process viscometers with respect to installation location. Since the viscosity measurement can be taken while the fluid is in motion during the processing application there are many possibilities for installation. All installation locations and techniques are not equally valid, however. There are several variables that must be taken into account to ensure that the viscosity reading is taken in the most authentic and meaningful way. This document details proper installation practices for a variety of different process environments.*

### Tanks/Vats

Many customers wish to check the viscosity of fluid while it is inside a medium to large size container as part of their standard quality control process before the fluid is used in production. For batch-to-batch viscosity measurements the simple approach is to use the sensor by dipping it into the process fluid container. If this is going to be the end use for the viscometer then depending on the size of the container it is recommended that it be mounted to a rod using a bracket at the end. For larger containers this will ease the measurement taking process and allow for measurements at consistent depths (very important for fluids that settle). For small to medium size containers this may not be necessary.

Other customers wish to measure fluid that is already in use in a process container. The fluid may be in motion and may or may not have temperature control. To obtain constant viscosity data the square format SenGenuity viscometers can be used with a

simple tank bracket consisting of a milled 2 inch diameter stainless steel tube with one end sealed and the other cut and bent. For conceptual purposes see the provided sketch figure which can be modified for any customer application. A window for the sensor to rest in is milled out near the sealed end and has a set screw hole directly behind it. This tube is fed down through a bracket made from ¼ inch stainless steel sheet stock and set in place with two more set screws. The sensor is fed through the tube, pressed in place with the set screw, and sealed in using silicone RTV or another sealant suitable to the process fluid. The mounting bracket secures to the top of the tank with two bolts and allows the customer to change the angle of attack between the sensor surface and the fluid as well as the depth. The importance of this adjustability will be discussed further.

In circumstances that allow it the low shear bolt viscometer can be used to monitor process tank viscosity by tapping a hole in the side of the tank and threading the bolt into it. There are several variables to consider in this mounting scenario and most are dependant on the fluid being measured. This method of mounting should not be used with fluids that are prone to surface build-up. Because the sensor is positioned below the surface of the fluid it is required that the tank be drained to below the level of the sensor port before it can be cleaned if needed. Thermal equilibrium should also be considered if the tank is kept at a different temperature than the environment. Depending on the thermal differential it may be necessary to insulate the exposed stainless steel of the bolt in order for it to obtain an accurate temperature measurement.

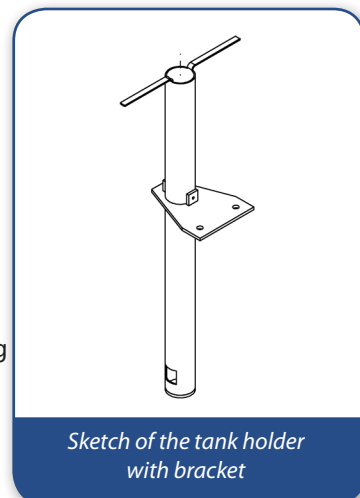

*Sketch of the tank holder  
with bracket*

## Pipes/Tubes

Installation procedures for pipe also vary with the size of the pipe. For pipes 3 inches and greater the simplest installation would be to use Sengenuity's low shear bolt viscometer and tap a hole in the side of the pipe to mount the sensor. This may be difficult in circumstances where the process must be running constantly. A section of pipe with flanges and shut-off valves can be made to mount the sensor that adds the benefit of allowing sensor removal while the pipe has fluid in it. The sensor should always be mounted on the side of the pipe since there may be deposits that build up on the bottom and air bubbles on the top, both of which could affect the viscosity readings.

For pipes 2 inches in diameter SenGenuity offers a specially designed section of pipe called the VisFlow that accepts the square viscometers and seals the sensing surface to the fluid using an o-ring. The section of pipe is 16 inches long and has male 2 inch NPT thread on both ends. It can be mounting into existing soft or hard tubing using a variety of available fittings.

For even smaller tubing SenGenuity offers a flow cell called the VisCell. This is a solid stainless steel bracket that holds the square viscometer in contact with the fluid using an o-ring. It has female ½ inch NPT holes for the process fluid to enter and exit the measurement chamber. The holes are oriented at a 45 degree angle of attack to the sensor surface to allow a consistent measurement. The unit also has 3 other ports, two ¼ inch and one ½ inch NPT, that allow the addition of other sensors including RTDs, pH probes, or pressure transducers into one flow cell sensing unit. These additional ports can be plugged when not in use.

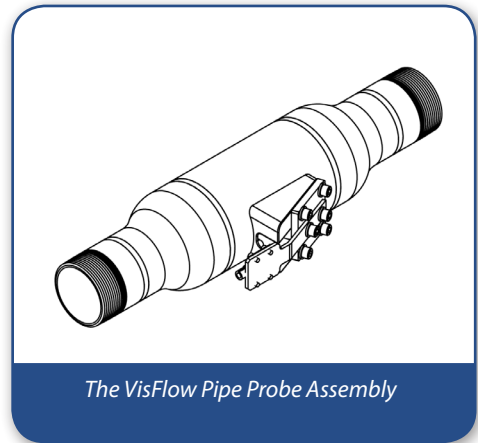

*The VisFlow Pipe Probe Assembly*

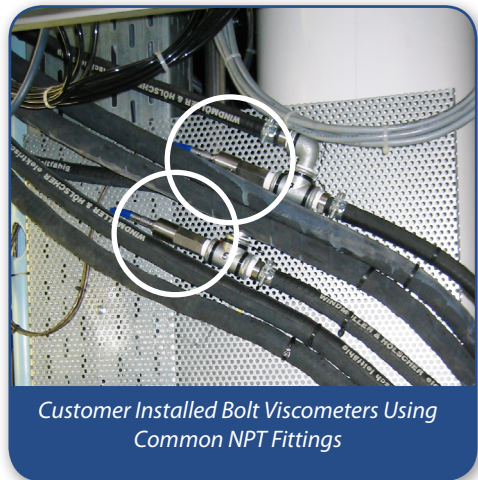

*Customer Installed Bolt Viscometers Using Common NPT Fittings*

## Other Mounting Considerations

Some fluids behave differently than others due to the mix of solvents in the fluid, number and size of particles, and the electrostatic charge on those particles. The SenGenuity digital viscometers measure a very small sample of the fluid, so in order for the measurement to be taken at the most valuable location one should take into account the sensor position with respect to the nature of the fluid. Some examples follow: If there is any amount of settling of the fluid then the sensor should not be mounted near the bottom of the tank or with the sensor surface facing up. Doing so would cause a drift in the viscosity readings over time as the fluid settles. If the fluid is in motion then the position of the sensor in the container being measured and the orientation of the sensor surface with respect to the fluid flow may also have an impact on the measurements taken depending on the nature of the fluid. The solution to this is to mount the sensor in a consistent position to allow for data correlation to historical measurement data. This should not be an issue in more Newtonian fluids such as oils and pure solvents.

The length of time that the sensor can remain in line is again determined by the nature of the fluid and the sensor mounting setup. Most applications can have the sensor installed in line and left in the process stream indefinitely. However, if the fluid is prone to leave deposits on the container/tubing that it dwells within then the sensor will have to be periodically removed and cleaned with another fluid that dissolves the build up. One would see this build up in the sensor readings as a drift in viscosity usually in the upward direction.

## Conclusions

There are as many sensing location possibilities as there are types of fluid out there and SenGenuity has a viscosity monitoring answer for each of them. The two sensor formats can be employed to find an in-line monitoring solution for almost every fluid bearing container imaginable. SenGenuity is focused on working with its customers to ensure the best mounting solution for every environment.

## Contact Information

If you would like to learn more about our sensors and the applications we address please contact our applications engineering group at [support@sengenuity.com](mailto:support@sengenuity.com).

## DISCLAIMER

Vectron International reserves the right to make changes to the product(s) and or information contained herein without notice. No liability is assumed as a result of their use or application. No rights under any patent accompany the sale of any such product(s) or information.